

FLUID POWER SYMBOL

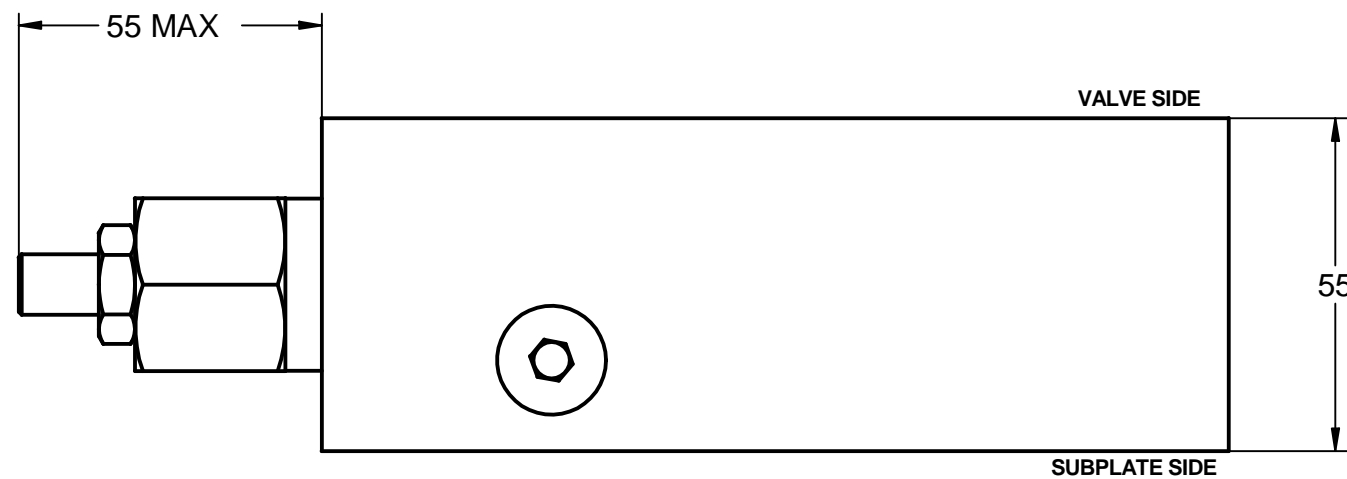

MODEL CODE

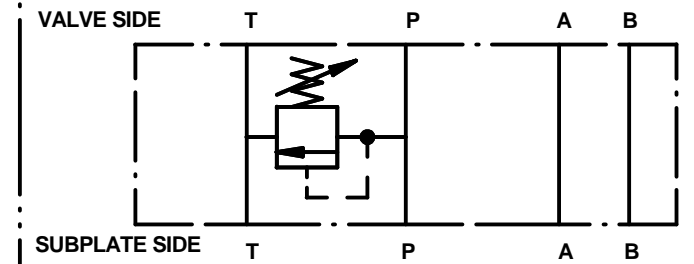
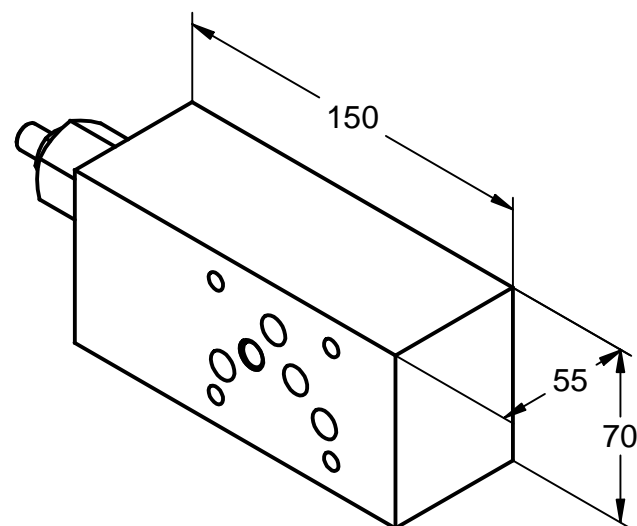
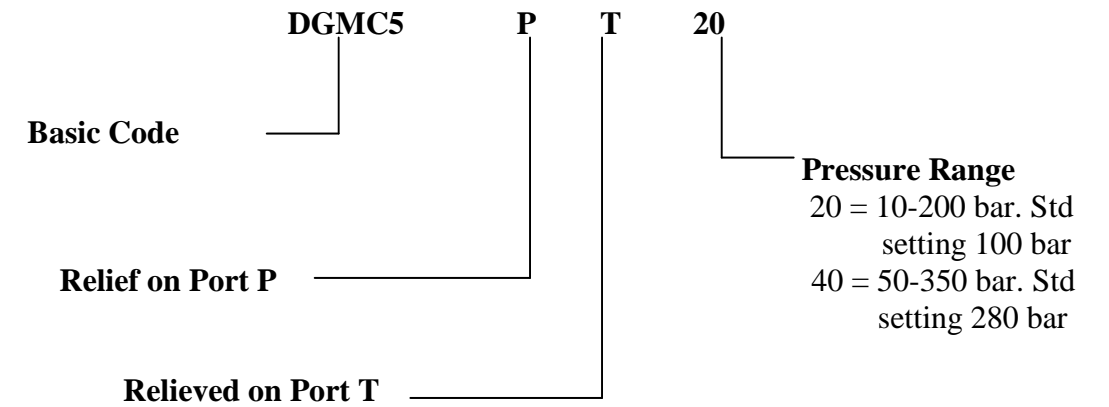

Valve Specification: -

1. This valve consists of a relief cartridge and manifold.
2. Maximum pressure is 400 bar.
3. Fluid Medium is Mineral Oil.
4. Maximum Flow is 150 lpm.

Tucson Hydrocontrols
 C1B 246/5 GIDC Estate, Umbergaon
 Gujarat 39 6171

DRAWN	PVD	CHKD	MJ
APRVD	PVD	DATE	

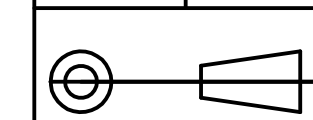

SCALE

DATA SHEET
CETOP5 MODULAR
RELIEF VALVE

DATA SHEET NO **010 140**