

SUBPLATE DIMENSION

MODEL CODE

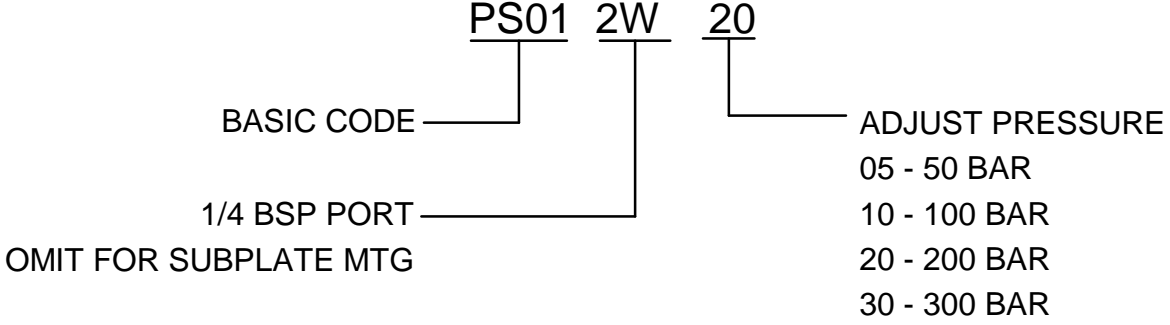

PRODUCT WEIGHT 1 KG

TS005

WIRING DIAGRAM

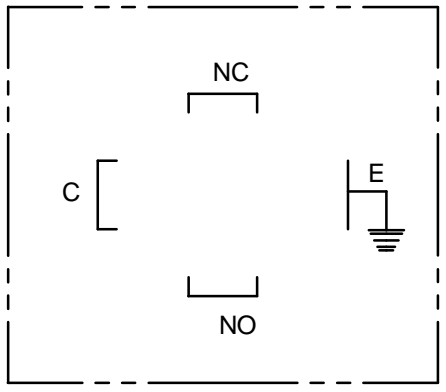

ELECTRICAL RATING

250 AC 5 AMPS

50 VDC 1 AMP

250V DC 0.2 AMPS

**Tucson Hydrocontrols**  
 C1B 246/5 GIDC Estate, Umbergaon  
 Gujarat 39 6171

DRAWN	PVD	CHKD	MJ
APRVD	PVD	DATE	
SCALE			

**DATA SHEET PS01**

DATA SHEET NO **010 400**