

**VALVE SPECIFICATION**

THIS CONSISTS OF CHECK CARTIDGE AND A SHUTTLE  
 MAX SERVICE PRESSURE IS 300 BAR  
 MAX FLOW IS 160 LPM  
 NITRILE SEALS ARE STANDARD  
 PILOT RATIO IS 3.0  
 VALVE CRACKING PRESSURE IS 1 BAR  
 MAX TEMPERATURE 80°C

**MODEL CODE  
 PC16 6W 20**

**PORT SIZES**  
 C 3/4 BSP  
 V 3/4 BSP  
 P 1/4 BSP

VALVE WEIGHT 1.8 KG

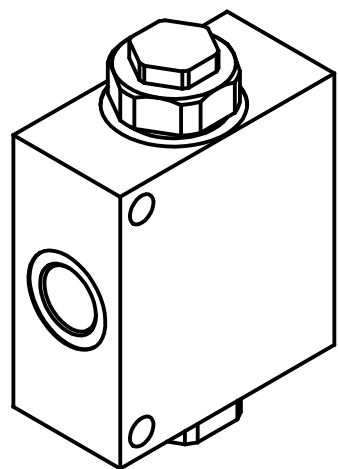

<b>Tucson Hydrocontrols</b>		
C1B 246/5 GIDC Estate, Umbergaon		
Gujarat 39 6171		
DRAWN PVD	CHKD RJPD	<b>DATA SHEET PILOT OPERATED CHECK VALVE PC16</b>
APRVD PVD	DATE	
		DATA SHEET NO <b>050 200</b>
SCALE		

TS003