

FLUID POWER SYMBOL

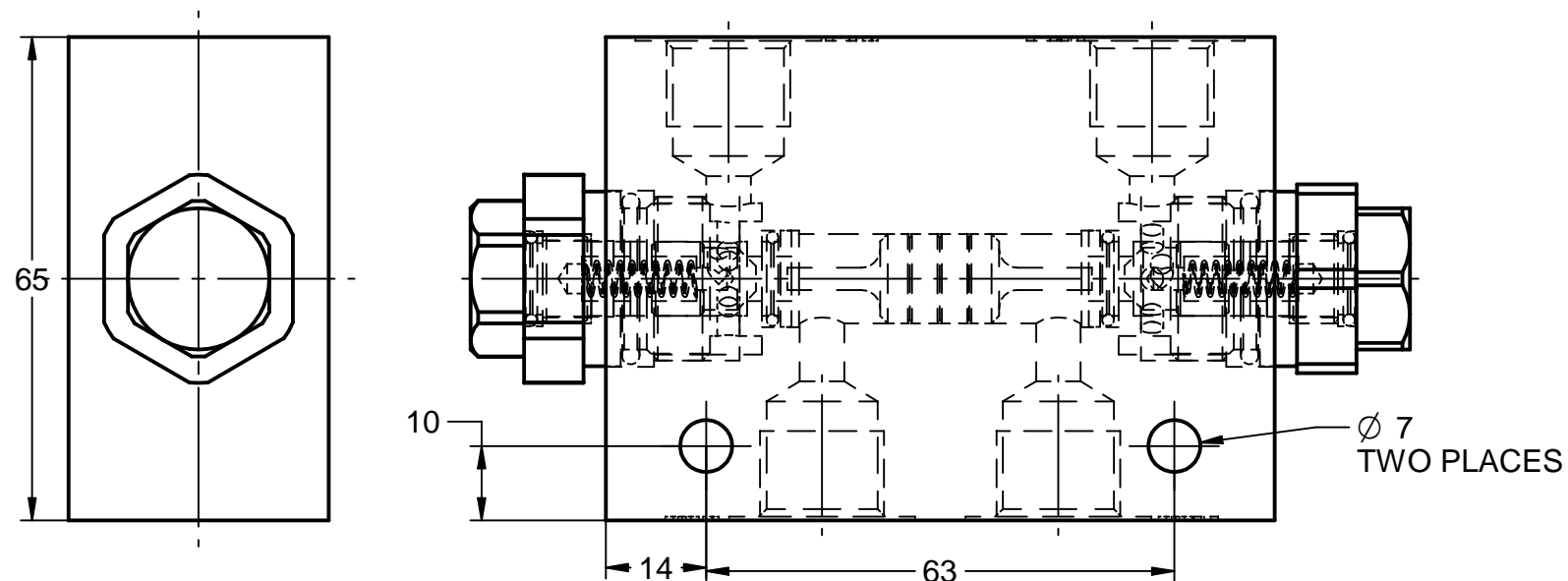

VALVE SPECIFICATION

THIS CONSISTS OF ALLUMINIUM BODY, CHECK CARTRIDGE AND A SHUTTLE
 MAXIMUM PRESSURE IS 250 BAR
 MAXIMUM FLOW IS 20 LPM
 PILOT RATION IS 3.00
 VALVE CRACKING PRESSURE IS 1 BAR
 MAXIMUM TEMPERATURE IS 80 DEGREES CENTIGRADE
 ALL PORTS 3/8 BSP TO A 7693

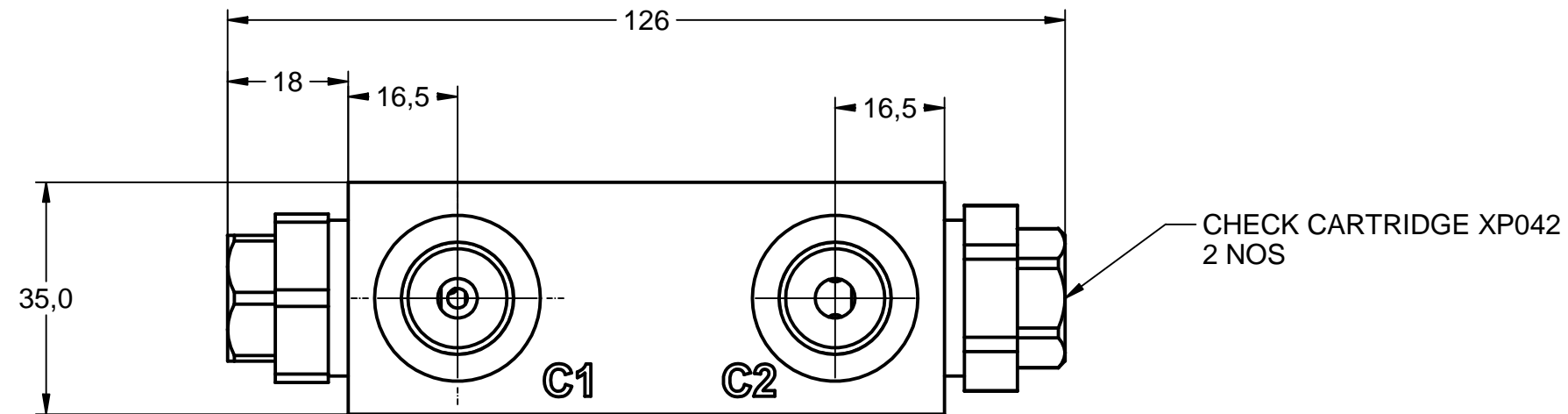
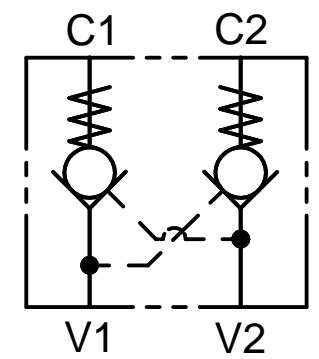
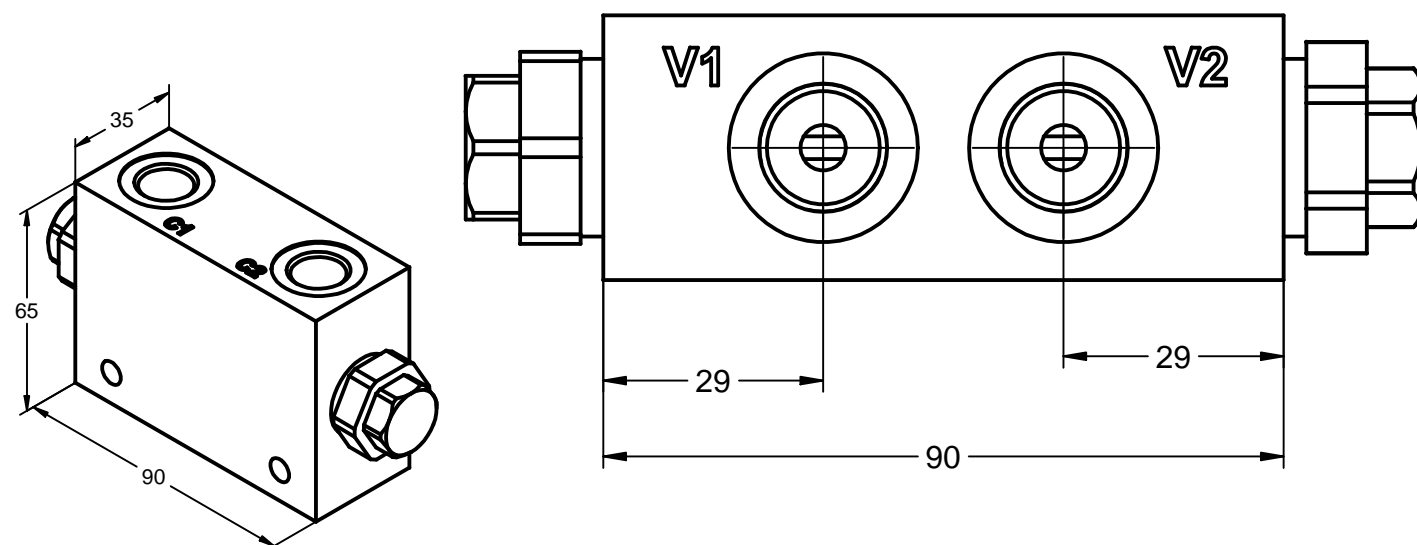

MODEL CODE DPC06 3W 25

Tucson Hydrocontrols
 C1B 246/5 GIDC Estate, Umbergaon
 Gujarat 39 6171

DRAWN	PVD	CHKD	MJ
APRVD	PVD	DATE	

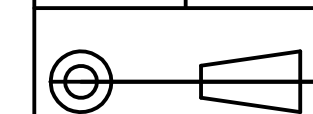

SCALE

**DATA SHEET
 DPC06**

DATA SHEET NO **050 358**

TS003