

**VALVE SPECIFICATION**

1. THIS VALVE CONSISTS OF CARTRIDGES AND A SHUTTLE INSIDE A MANIFOLD
2. MAXIMUM SERVICE PRESSURE IS 300 BAR.
3. FLUID MEDIUM IS MINERAL OIL
4. MAXIMUM OPERATING TEMPERATURE IS 80 DEGREES
5. PILOT RATIO IS 3
6. CHECK VALVE CRACKING PRESSURE IS 1 BAR.
7. MAXIMUM FLOW IS 60 LPM.

**MODEL CODE  
DGMPC5 ABK BAK 30**

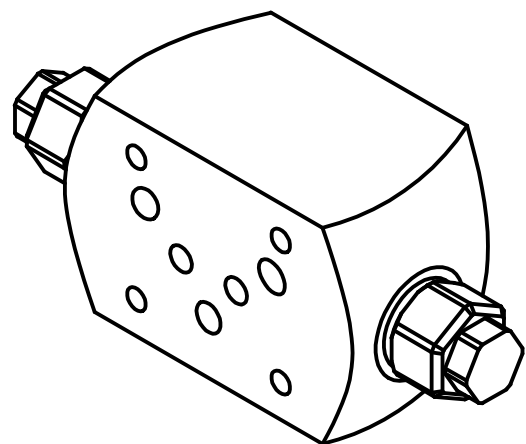

**Tucson Hydrocontrols**  
C1B 246/5 GIDC Estate, Umbergaon  
Gujarat 39 6171

|       |     |      |    |
|-------|-----|------|----|
| DRAWN | PVD | CHKD | MJ |
| APRVD | PVD | DATE |    |

**DATA SHEET  
DGMPC5 ABK BAK 30**

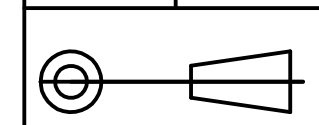

SCALE

DATA SHEET NO **050 410**

TS011